

PLASTIC HANDLES & ACCESSORIES

Product Specification Sheet

196 Valois,
Vaudreuil-Dorion, Quebec
Canada J7V 1T4
866-455-0040 Fax 450-455-0030
info@plastic-handle.com

Product Group: **Multipack Carriers**
Sub Group: **B334.28L Series**
Item: **3 Pack Bail 28mm Cap**

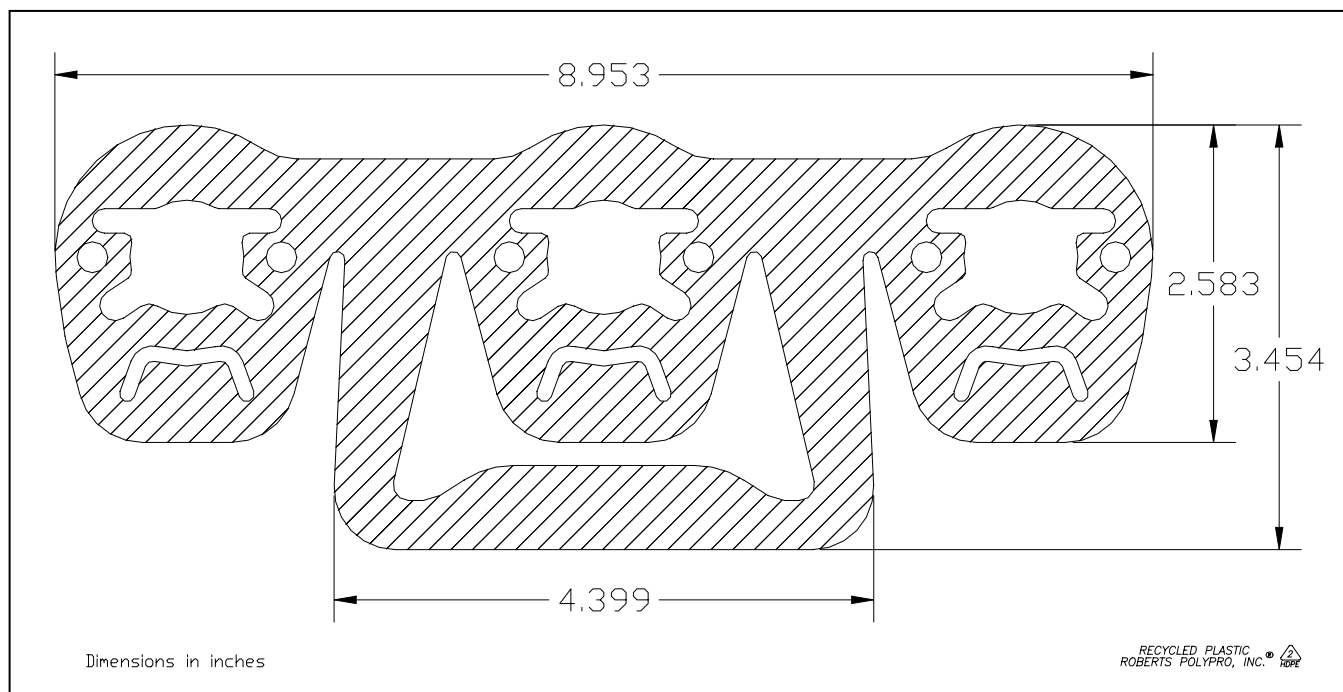

Current Product Numbers

B334.28L.NAT Loose, Natural Tab Style Carrier
Custom Ask us about customizing a carrier to meet your specifications

Quality Specifications

Material:	High Density Polyethylene
Thickness:	0.035" ± 0.001"
Flatness Gauge:	1 Part Thickness
Surface Finish:	Gloss
Part Weight:	9.72 grams

Packaging Information

Case Quantity:	<i>Loose:</i> 1,500	<i>Welded:</i> N/A
Case Dimensions:	<i>Loose:</i> 22.625" x 9.5" x 9"	<i>Welded:</i> N/A
Pads per Case:	<i>Loose:</i> 6	<i>Welded:</i> N/A
Pad Dimensions:	<i>Loose:</i> 5 @ 8.688" x 8.75" & 1 @ 8.75" x 22.5"	<i>Welded:</i> N/A
Case Weight:	<i>Loose:</i> 34.1 lbs	<i>Welded:</i> N/A
Pallet Weight:	<i>Loose:</i> 1,950 lbs	<i>Welded:</i> N/A
Cases per Pallet:	<i>Loose:</i> 56	<i>Welded:</i> N/A

Packaging Notes: *Loose* - A 64BP pad is placed on the bottom of a 96C carton, followed by 6 vertical stacks of 250 parts. Each stack is separated by a vertical 96P pad (5) total. Then the carton is sealed. A full pallet load consists of a 40" x 48" pallet with 7 layers of 8 cartons with 1500 parts per carton or 84,000 parts per pallet load. A 40" x 48" pallet pad is used between the 4th and 5th layers. *Welded* - N/A