

PLASTIC HANDLES & ACCESSORIES

196 Valois,
Vaudreuil-Dorion, Quebec
Canada J7V 1T4
866-455-0040 Fax 450-455-0030
info@plastic-handle.com

Product Specification Sheet

Product Group: **Multipack Carriers**
Sub Group: **B254.43L Series**
Item: **2 Pack Tab 96 oz (Short)**

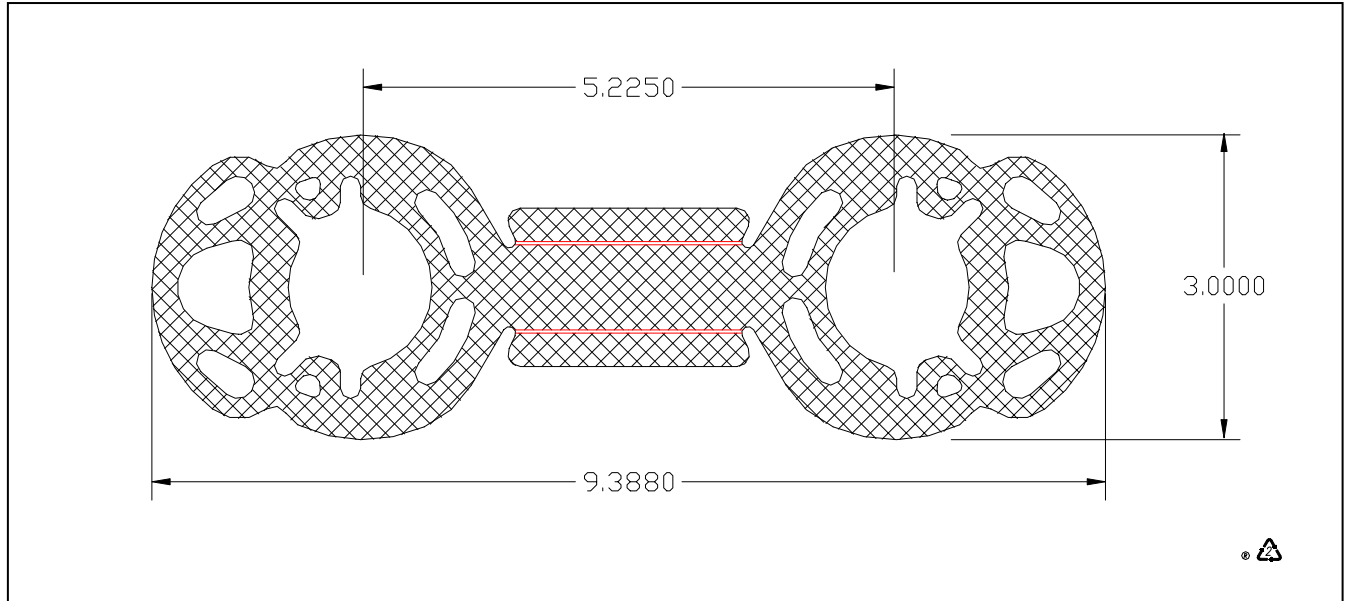

Current Product Numbers

B254.43L.NAT Loose, Natural Tab Style Carrier
Custom Ask us about customizing a carrier to meet your specifications

Quality Specifications

Material: High Density Polyethylene
Thickness: 0.050" ± 0.001"
Flatness Gauge: 1 Part Thickness
Surface Finish: Gloss
Part Weight: 11.6 grams

Packaging Information

Case Quantity:	<i>Loose:</i> 1,200	<i>Welded:</i> N/A
Case Dimensions:	<i>Loose:</i> 22.625 x 9.5 x 9	<i>Welded:</i> N/A
Pads per Case:	<i>Loose:</i> 7	<i>Welded:</i> N/A
Pad Dimensions:	<i>Loose:</i> 8.688 x 8.75	<i>Welded:</i> N/A
Case Weight:	<i>Loose:</i> 27.5 lbs	<i>Welded:</i> N/A
Pallet Weight:	<i>Loose:</i> 1,580 lbs	<i>Welded:</i> N/A
Cases per Pallet:	<i>Loose:</i> 72	<i>Welded:</i> N/A

Packaging Notes: *Loose* - A pad is placed on the bottom of a 96C carton, followed by seven vertical stacks of 172 parts. Each stack is separated by a vertical 96P pad. Then the carton is sealed. A full pallet load consists of a 40" x 48" pallet with 9 layers of 8 cartons with 1200 parts per carton or 67,200 parts per pallet load. A 40" x 48" pallet pad is used between the 5th and 6th layers. *Welded* - N/A.